

● ANB



Features

Buffer type ANB consists of a cylindrical rubber body bonded to a square baseplate of steel. Each corner of the baseplate has a fixing hole.

Special high-hysteresis rubber compound is used to ensure as much energy absorption as possible. The volume of the rubber is used at optimum efficiency.

For new machine developments simpler designs and lighter calculated forces can be considered enabling a lower cost.

Novibra® type ANB

The shockbuffer type ANB is used to effectively limit movement of equipment or machine components.

Typical field applications would be:

- Wagons
- Traversing cranes
- Lifting cranes
- Working beams
- Falling goods
- Container handling equipment
- Cabinets
- Forestry vehicles
- Off-road material handling equipment

Through the low resilience of the rubber a high degree of energy absorption is achieved. The rubber is stiffer under dynamic conditions compared to static or pseudo static loading; hence more energy is absorbed for a given deformation. Diagram 4 shows the effect of the energy factor.

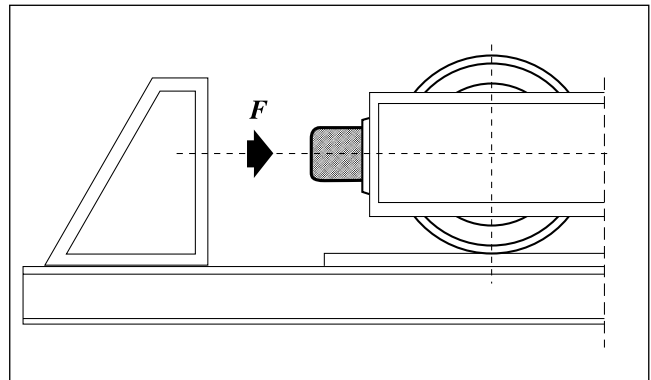

Fig. 1. Traverse crane with shock buffer ANB.

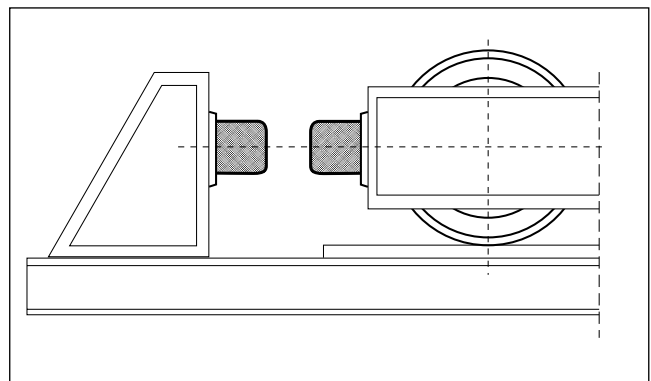

Fig. 2. Traverse crane with 2 ANB buffers connected in series.

Type	Part no.	K	A	Dimensions in mm				Weight (kg)	F-Max (N)
				D	d	H	t		
ANB 50	10-00151-01	70	50	50	7	43	3	0.2	8000
ANB 75	10-00152-01	100	75	75	9	63	3	0.5	20000
ANB 100	10-00153-01	130	100	100	11	84	4	1.2	41000
ANB 150	10-00010-01	185	150	150	13.5	126	6	3.9	90000
ANB 200	10-00011-01	240	200	200	13.5	168	8	9.1	180000