

## Flanged Instrumountings ●



### Features

- Fail-safe when fitted with overload and rebound washers of the same diameter as the rubber section.
- Load range from 2.7 to 5.4 kg.
- Static deflection up to 3 mm.
- Easy to fit as part of a cabinet enclosure.
- Can be used in both vertical directions.

### Metalastik® type Flanged Instrumountings

These mountings are suitable for both mobile and static applications, for the protection of sensitive equipment from external vibration or for vibration isolation of small fan sets, transformers and similar equipment. Flanged Instrumountings can be fail-safe if fitted with a washer to the top and bottom of the rubber section.

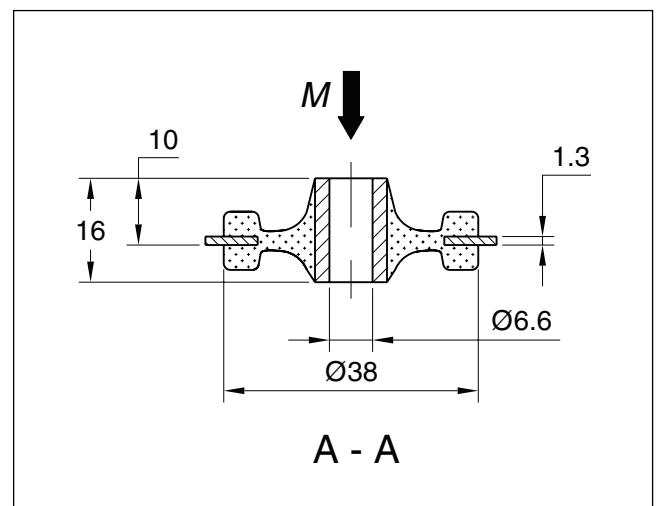
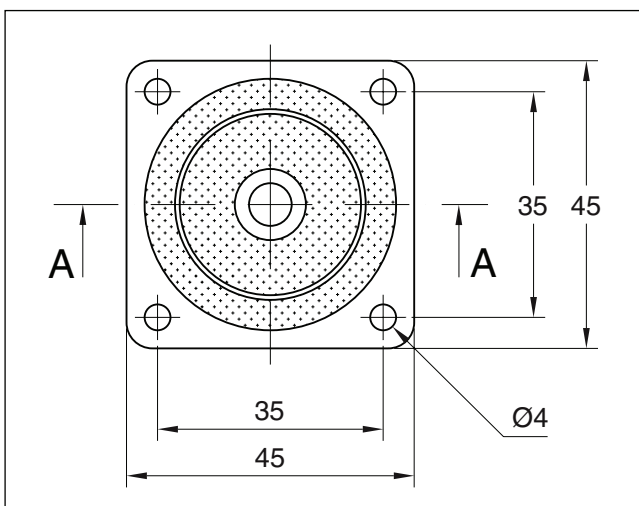

	Part no.	M-Max (kg)	Weight (kg)
17-1801-45	10-00583-01	2.7	0.03
17-1801-60	10-00584-01	5.4	0.03