

● Metacone™ & HK



Metalastik® type Metacone™ and Novibra® type HK

A range of mountings designed for high load capacity with relatively large static deflections. The high loading for a given size is achieved by utilising the rubber to best advantage in shear and compression. Normally, mountings are assembled with overload and rebound washers to control and limit movement of the suspended equipment under shock loads. Centre fixing bolts should be torque tightened to the recommended values.

Applications include suspensions for:

- Off-road and road vehicle engines
- Vehicle Cabs
- Oil Tanks/Tankers
- Mobile applications

Type Metacone™	Part no.	Max vert. load (kg)	Weight (kg)
17-0189-45	10-00365-01	145	0.28
17-0189-70	10-00367-01	400	0.28
17-0241-45	10-00374-01	62	0.18
17-0241-60	10-00375-01	122	0.18
17-0248-45	10-00379-01	95	0.19
17-0248-60	10-00380-01	190	0.19
17-0277-45	10-00385-01	125	0.56
17-0277-60	10-00387-01	230	0.56
17-0379-45	10-00402-01	35	0.12
17-0379-60	10-00404-01	70	0.12
17-0341-45	10-00394-01	160	0.54
17-0341-60	10-00395-01	300	0.54
17-0341-70	10-00396-01	430	0.54
17-0311-45	10-00391-01	125	0.58
17-0311-60	10-00392-01	220	0.58
17-1691-45	10-00566-01	72	0.44
17-1691-60	10-00567-01	144	0.44
HK 60-40	10-01119-01	90	0.24
HK 60-50	10-01122-01	115	0.24
HK 60-60	10-01120-01	180	0.24
HK 60-70	10-01121-01	250	0.24

Features

A compact fail safe design, available for a wide range of loadings with in some cases alternative fixings.

Cutouts in rubber section on various sizes provide different vertical/horizontal stiffness ratios.

Most sizes can be supplied complete with overload and rebound washers.

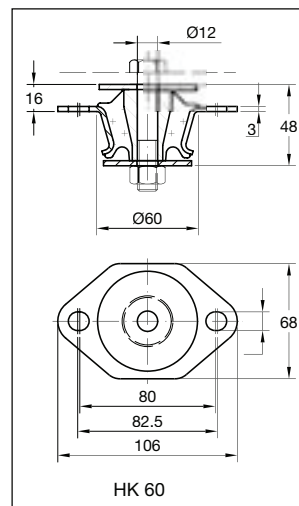
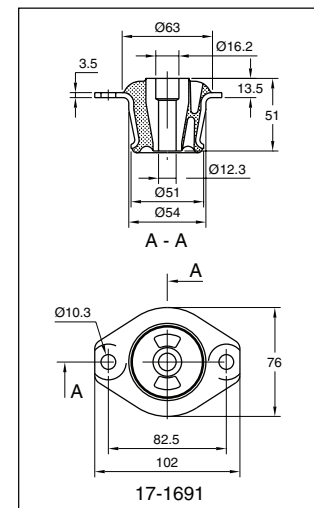
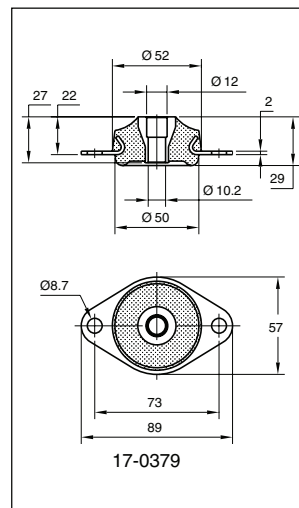
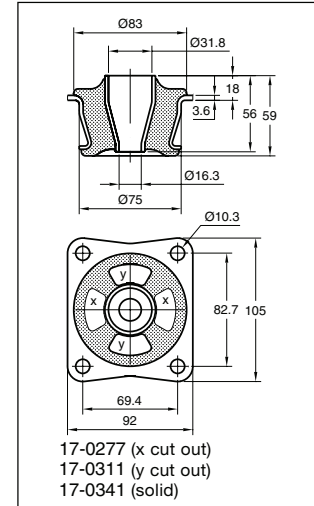
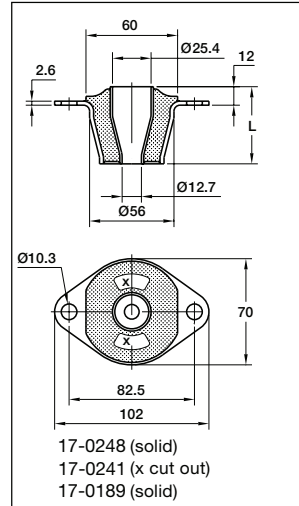

Type	Cone mount	Top washer Part no.	Bottom washer Part no.
Metacone™	17-0189	20-00529-01	10-03666-01
	17-0241	20-00529-01	10-03666-01
	17-0248	20-00529-01	10-03666-01
	17-0277	20-00773-01	20-00532-01
	17-0379	20-00531-01	20-00531-01
	17-0341	20-00773-01	20-00532-01
	17-0311	20-00773-01	20-00532-01
	17-1691	20-00535-01	20-00536-01
HK	HK 60	20-01103-01	20-00416-01

● Metacone™ & HK

**Metalastik®
type Metacone™
and Novibra® type HK**

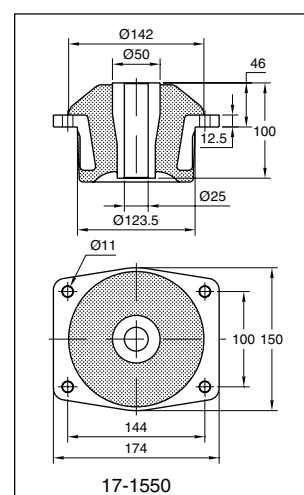
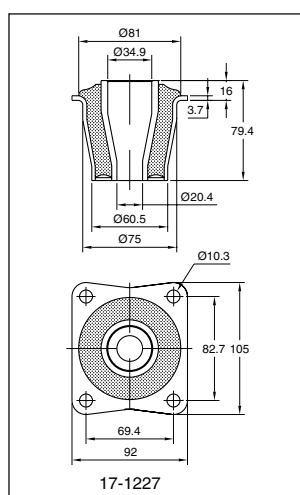
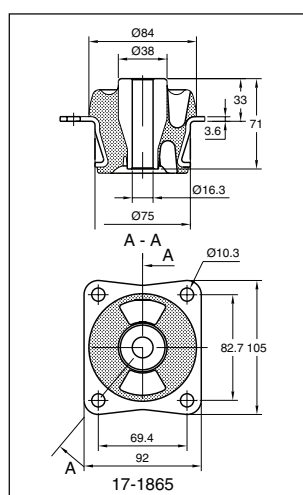
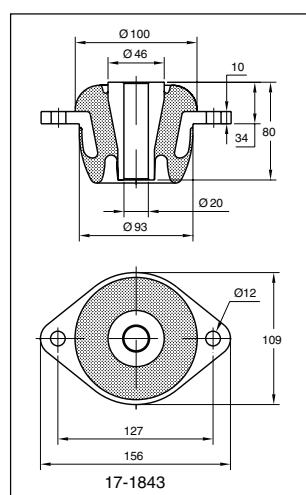
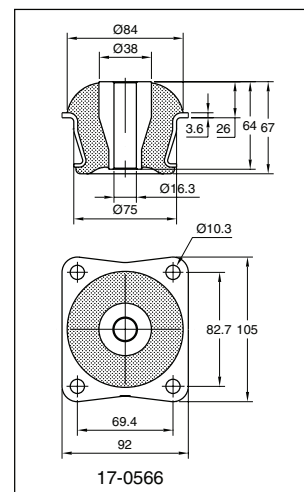
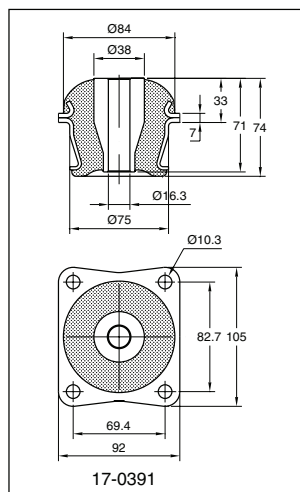
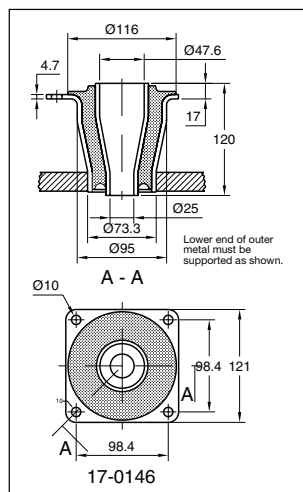

Type Metacone™	Part no.	Max vert. load (kg)	Weight (kg)
11-1009-45	10-00192-01	140	0.59
11-1009-55	10-00193-01	200	0.59
17-0391-45	10-00411-01	290	1.1
17-0391-60	10-00414-01	500	1.1
17-0391-70	10-00415-01	610	1.1
17-0566-45	10-00433-01	200	0.82
17-0566-60	10-00434-01	380	0.82
17-0566-70	10-00435-01	525	0.82
17-1227-45	10-00459-01	560	1.1
17-1227-60	10-00460-01	1000	1.1
17-1550-45	10-00524-01	720	4.4
17-1550-60	10-00526-01	1250	4.4
17-1843-45	10-00609-01	320	1.7
17-1843-60	10-00610-01	600	1.7
17-1865-55	10-00615-01	180	0.86
17-0146-45	10-00360-01	950	2
17-0146-60	10-00361-01	1700	2
HK 600-40	10-00190-01	940	1.0
HK 600-60	10-00191-01	1700	1.0

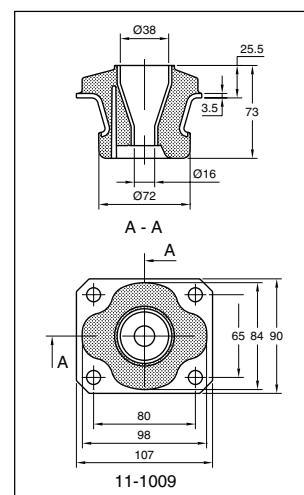
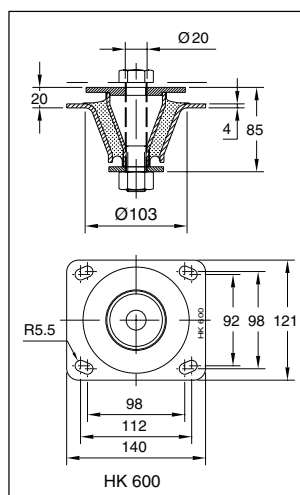

Type	Cone mount	Top washer Part no.	Bottom washer Part no.
Metacone™	11-1009	20-00532-01	20-00532-01
	17-0391	20-00532-01	20-00532-01
	17-0566	20-00532-01	20-00532-01
	17-1227	20-00528-01	10-03707-01
	17-1550	20-00534-01	20-00534-01
	17-1843	20-00533-01	20-00533-01
	17-1865	20-00532-01	20-00532-01
	17-0146	20-00527-01	20-00525-01
HK	HK 600	20-00643-01	20-00644-01

Top and bottom washers

Overload and rebound washers (top and bottom) are necessary to limit maximum movement in the event of shock loading.

Type A
Steel Washer

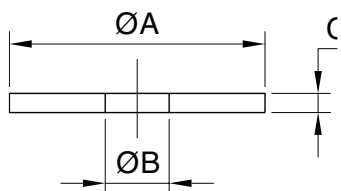

Type B
Top Stepped Steel Washer

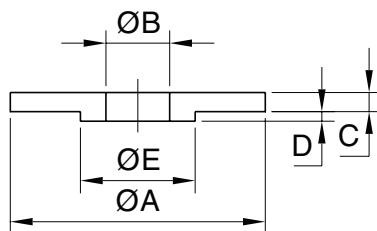

Type C
Rebound Washer with Rubber

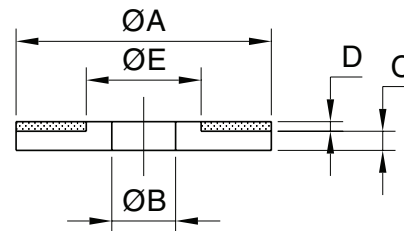

Washer

Designation	Part no.	Type	Dimensions in mm				
			A	B	C	D	E
Washer 50x12C	10-03666-01	C	50	12	3	3	28.5
Washer 95x24C	20-00525-01	C	95	24	8	6	38
Washer 67.5x20C	10-03707-01	C	67.5	20	5	5	30
Washer 116x24B	20-00527-01	B	116	24	8	4	47
Washer 80x20B	20-00528-01	B	80	20	6	3	34.5
Washer 55x12B	20-00529-01	B	55	12	5	2.5	25
Washer 80x16B	20-00773-01	B	80	16	6.5	3	31.5
Washer 50x10A	20-00531-01	A	50	10	4		
Washer 80x16A	20-00532-01	A	80	16	5		
Washer 100x20A	20-00533-01	A	100	20	6		
Washer 139x24A	20-00534-01	A	139	24	10		
Washer 55x12A	20-00535-01	A	55	12	5		
Washer 51x16A	20-00536-01	A	51	16	4		
Washer 57x12A	20-01103-01	B	57	16	3	1.5	22
Washer 52x12A	20-00416-01	A	52	16	3		
Washer 110x20B	20-00643-01	B	110	20	5	3	52.5
Washer 55x20A	20-00644-01	A	55	20	5		

Recommended tightening torque for center fixing bolts	
Thread size	Torque (Nm)
M10	25
M12	40
M16	60
M20	120
M24	200

Metacone™ and HK on page 40

Type	Cone mount	Top washer Part no.	Bottom washer Part no.
Metacone™	17-0189	20-00529-01	10-03666-01
	17-0241	20-00529-01	10-03666-01
	17-0248	20-00529-01	10-03666-01
	17-0277	20-00773-01	20-00532-01
	17-0379	20-00531-01	20-00531-01
	17-0341	20-00773-01	20-00532-01
	17-0311	20-00773-01	20-00532-01
	17-1691	20-00535-01	20-00536-01
	HK	HK 60	20-01103-01

Metacone™ and HK on page 42

Type	Cone mount	Top washer Part no.	Bottom washer Part no.
Metacone™	11-1009	20-00532-01	20-00532-01
	17-0391	20-00532-01	20-00532-01
	17-0566	20-00532-01	20-00532-01
	17-1227	20-00528-01	20-00526-01
	17-1550	20-00534-01	20-00534-01
	17-1843	20-00533-01	20-00533-01
	17-1865	20-00532-01	20-00532-01
	17-0146	20-00527-01	20-00525-01
	HK	HK 600	20-00643-01