



**Novibra® type SIM™**

Type SIM™ is used for vibration isolation of small to medium sized machines:

- Fans
- Pumps
- Compressors
- Refrigeration and air-conditioning
- Engines
- Measurement equipment

- Marine propulsion engines

**Features**

SIM is a mounting for mobile applications. The strong metal parts and the soft vertical stiffness combined with high stiffness in the longitudinal direction makes it suitable for suspension of marine engines both with and without thrust bearing.

Its unique construction and the latest production methods make Novibra type SIM a high performance mounting having a number of advantages.

- Low vertical natural frequency 8-9 Hz combined with high longitudinal stiffness, ratio approx  $k_l/k_v=3.5-5.5$ .
- Special designed stronger bottom plate and top cover to withstand high shock loads from tough mobile applications.
- Load range from 50-580 kg.
- Fitted as standard with a shock proof device (up to 5 g) with resilient stop.
- Corrosion protected to cope with arduous environments with treatment Fe/Zn8C as per ISO 2081.
- SIM can be delivered with two types of height adjusters, one standard type HA and one special for higher load requirements.
- Clear and durable product marking. Mountings can be identified after several years in operation.
- Domed shape top cover to protect against oil contamination.

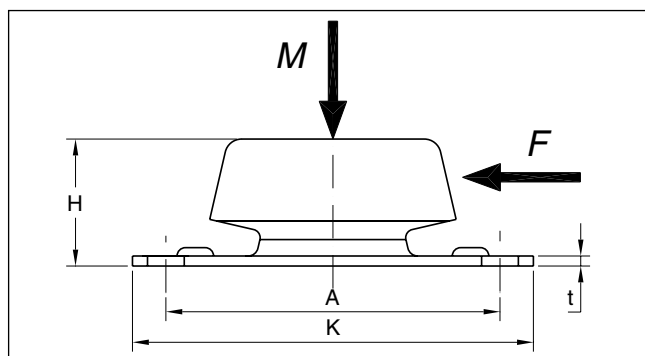

Protected and registered design

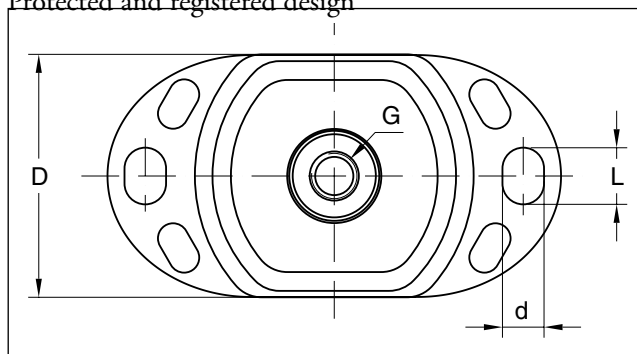

Type	Part no.	Max load <i>M</i> (kg)	Max longitudinal force <i>F</i> (N)	Dimensions in mm								Weight (kg)
				D	A	K	H	d	L	t	G	
SIM 100-40	10-00043-01	50	750	64	100	120	38	11	15	3	M12	0,35
SIM 100-50	10-00046-01	60	1000									
SIM 100-60	10-00044-01	100	1400									
SIM 100-70	10-00045-01	130	2000									
SIM 200-40	10-00047-01	100	2000	75	140	175	50	13	20	4	M16	0,75
SIM 200-50	10-00050-01	150	3000									
SIM 200-60	10-00048-01	230	4500									
SIM 200-70	10-00049-01	310	6000									
SIM 300-40	10-00051-01	220	5000	112	182	216	70	18	26	5	M20	2,03
SIM 300-50	10-00054-01	300	6500									
SIM 300-60	10-00052-01	460	9000									
SIM 300-70	10-00053-01	580	12000									