

Tapered Mount

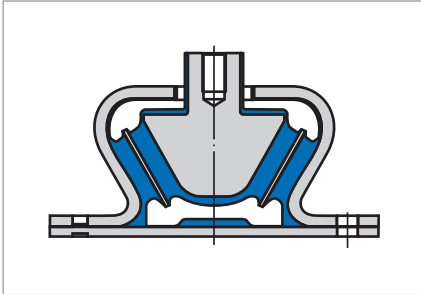

Fig. 1 Tapered Mount

Material

Standard material	Hardness
Natural rubber NR 39	40, 42, 45, 50, 60 Shore A

Operating conditions

Compressive forces in Z direction	1750 N ... 14000 N	Maximum permissible force
Max. temperature	+80 °C, transient +100 °C	
Min. temperature	-45 °C	

Product description

Tapered mounts are used primarily to carry light, medium and heavy engines for mobile and stationary applications.

Product advantages

- Robust
- Slight settling on compressive deflection in the Z direction
- Effective limitation of compressive and rebound deflection
- Limitation of horizontal spring displacement
- Narrow, ideal for mounting on steel sections
- RoHS-compliant.

Application

Tapered mounts can be utilised for agricultural and construction machinery. They are also suited for mounting generators of ships' engines.

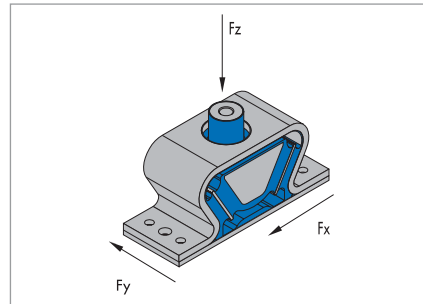

Fig. 2 Primary load directions

Tapered mounts have limiters for deflection in all spatial directions whereby the deflection in the Z direction is especially robust. In compressive-deflection direction Z, the mount also has a "soft" end stop. The stiffness depend primarily on the thickness, length, height and the wedge angle to the Z axis. Through the use of intermediate metal sheets, the Z stiffness, for example, is at least doubled for the same operating environment. The primary static load should be perpendicular to the planes of attachment.

Design notes

The tapered mount comprises an outer omega-shaped bracket with flange and through-hole. An inner metal part with threaded hole partially plunges through a borehole of the bracket. Elastomer pads are vulcanised between both metal parts in Vee shape.

Fitting & installation

- Tapered mounts are designed to be secured by means of threaded fasteners
- Avoid non-load-dependent offset of the inner metal part relative to the flange
- Individual components permit slight adjustment to allow for in-situ offset
- It is important to ensure that the mating faces of the frame and the mass carried by the mount are paralleled, flat and smooth.

Article list

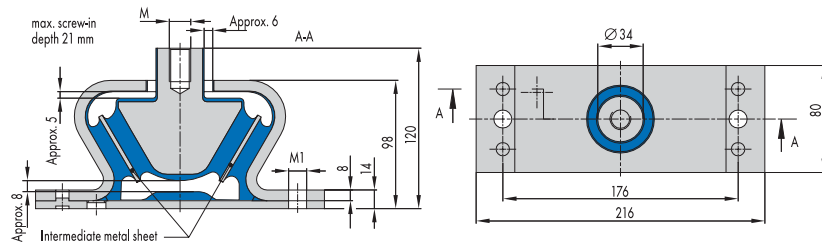

Fig. 3 Tapered Mounts 033 18 720, 033 18 730

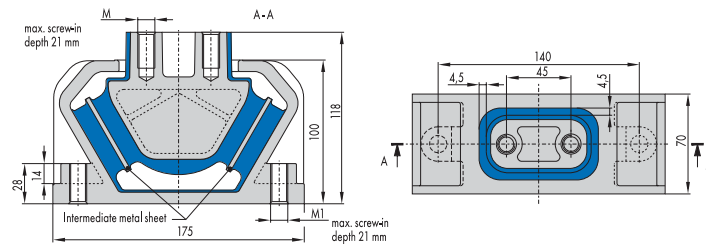

Fig. 4 Tapered Mounts 033 18 700, 033 18 701

Nominal maxima		Stiffness			Threads top	Threads base	Product No.	Material		Inter-mediate metal sheet	Article No.	
F _z max	S _z max	c _z	c _x	c _y	M	M1		Rubber	Metal			
[N]	[mm]	[N/mm]	[N/mm]	[N/mm]								
2200	5	440	1700	500	M12	M12	033 18 700	42 NR 39	aluminium	without	511470	○
3400	5	680	2600	770	M12	M12	033 18 700	50 NR 39	aluminium	without	2129315	○
5300	5	1060	4000	1200	M12	M12	033 18 700	60 NR 39	aluminium	without	2129317	○
5800	5	1160	4500	1300	M12	M12	033 18 701	45 NR 39	aluminium	with	2129378	○
8900	5	1780	6900	2000	M12	M12	033 18 701	50 NR 39	aluminium	with	2129321	○
14000	5	2800	10800	3200	M12	M12	033 18 701	60 NR 39	aluminium	with	2129323	○
4500	5	900	3200	185	M16	Ø13,5	033 18 720	40 NR 39	steel	with	49025343	●
6000	5	1200	4800	280	M16	Ø13,5	033 18 720	50 NR 39	steel	with	49025344	●
10000	5	2000	8000	465	M16	Ø13,5	033 18 720	60 NR 39	steel	with	49025345	●
1750	5	350	700	100	M16	Ø13,5	033 18 730	40 NR 39	steel	without	49025346	●
2920	5	580	1400	200	M16	Ø13,5	033 18 730	50 NR 39	steel	without	49025347	●
4000	5	800	2400	330	M16	Ø13,5	033 18 730	60 NR 39	steel	without	49025348	●

● Available from stock ○ On request: Tool is available, delivery at short notice